

Product Data Sheet  
Zone Control Valve Assembly  
Impulse solenoid valve  
**TUNPROTEC**<sup>®</sup>  
FIXED FIRE FIGHTING  
SYSTEMS  
For road and rail tunnels

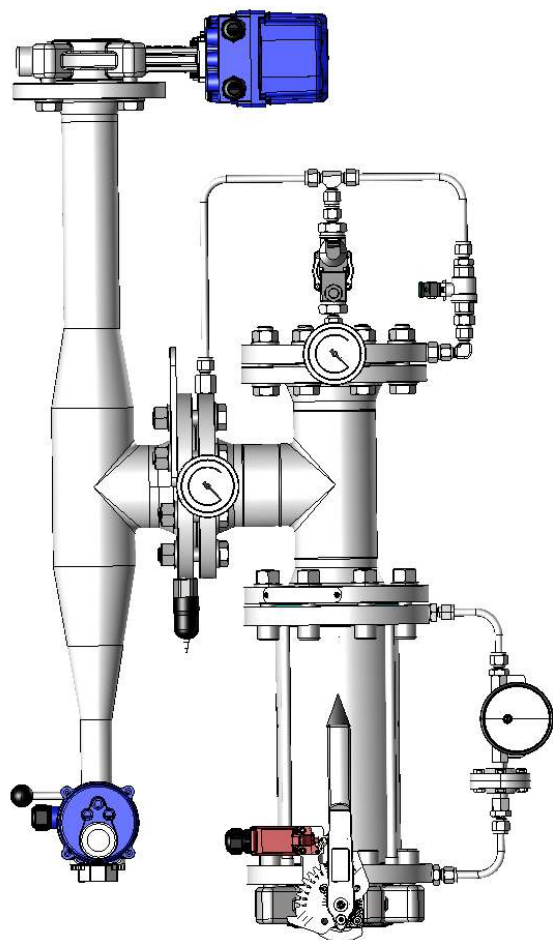

## Description

The TUNPROTEC Model Tunprotec C-A-80-50-I Zone Control Valve assembly is a factory-assembled and -tested fire zone control valve, designed for implementation in TUNPROTEC systems.

As fire zone control valve, the Model Tunprotec C-A-80-50-I Zone Control Valve has been designed to hydraulically control the flow of water from the wet supply system to the dry TUNPROTEC N-Pipe low pressure water mist system.

The valve assembly includes:

1. Service Valve
2. Tamper switch (Service Valve position)
3. Zone control valve
4. DIN control box (optional)
5. Actuator for motorized drain valve
6. High-capacity filter
7. Actuator for motorized outlet
8. Service- and test valve Downstream
9. Pressure switch
10. Solenoid Valve
11. Drain- and test valve

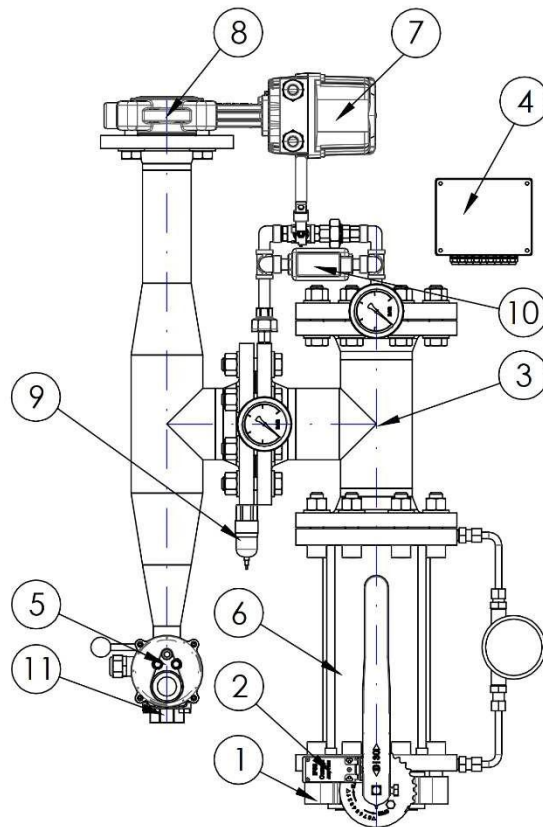

The Model Tunprotec C-A-80-50-I features small outer dimensions, robust and reliable components, and the ability to remotely activate the zone control valve and to have it run a self-test sequence in which activation and alarm functions can be tested.

The fire zone control valve is shipped fully assembled and can be easily installed into protected areas or into cabinets.

## Application

The Model Tunprotec C-A-80-50-I Zone Control Valve is designed and tested for installation in infrastructure tunnels of unlimited length. Among approved applications are road, train, metro, cable, conveyor, mining, and pedestrian tunnels.

## Approvals

The zone control valve (3) has been successfully component tested by FM Approvals.

TUNPROTEC system is holding IBS Institute für Brandschutztechnik und Sicherheitsforschung approval.

Technical data	
Max. working pressure	16 bars
Kv-value	1800 l/min/√(bar)
Material	AISI 316
Hydraulic connections	1x DN80 Flanged inlet 1 x DN50 Flanged outlet 1x 1" BSP (Drain)
Electrical components:	Solenoid valve: 24 VDC
	Downstream service/test valve actuator: 24 VDC, 36W,
	Drain/test actuator: 24 VDC,
	Tamper Switch: 1NO+1NC,
	Pressure indicator: 24V, NO/NC,
Sales and order number	TPT-10931 / C-A-80-50-I

## Installation

Once received the Zone Control Valve shall be stored under safe conditions, protected from harmful materials and physical damages.

Prior to installation of the Model Tunprotec C-A-80-50-I Zone Control Valve, the pipe system to be connected shall be flushed and rinsed, and the area in which the valve assembly is to be installed into shall be checked to not interfere with the valve assembly and its functions.

When installing Model Tunprotec C-A-80-50-I Zone Control Valve, the valve assembly shall first be fixed in place using approved brackets or pipe-hangers and then fixed to the connecting flanged inlet and outlet connections, after which the threaded drain connections can be connected to a general drain system and the control box can be connected to detection and control systems.

NOTE: The complete piping system upstream to the valve assembly including the pilot chamber shall be completely water filled prior to starting any pump.

NOTE: The fire pump shall always be stopped prior to closing the Zone Control Valve.

**Dimensions**

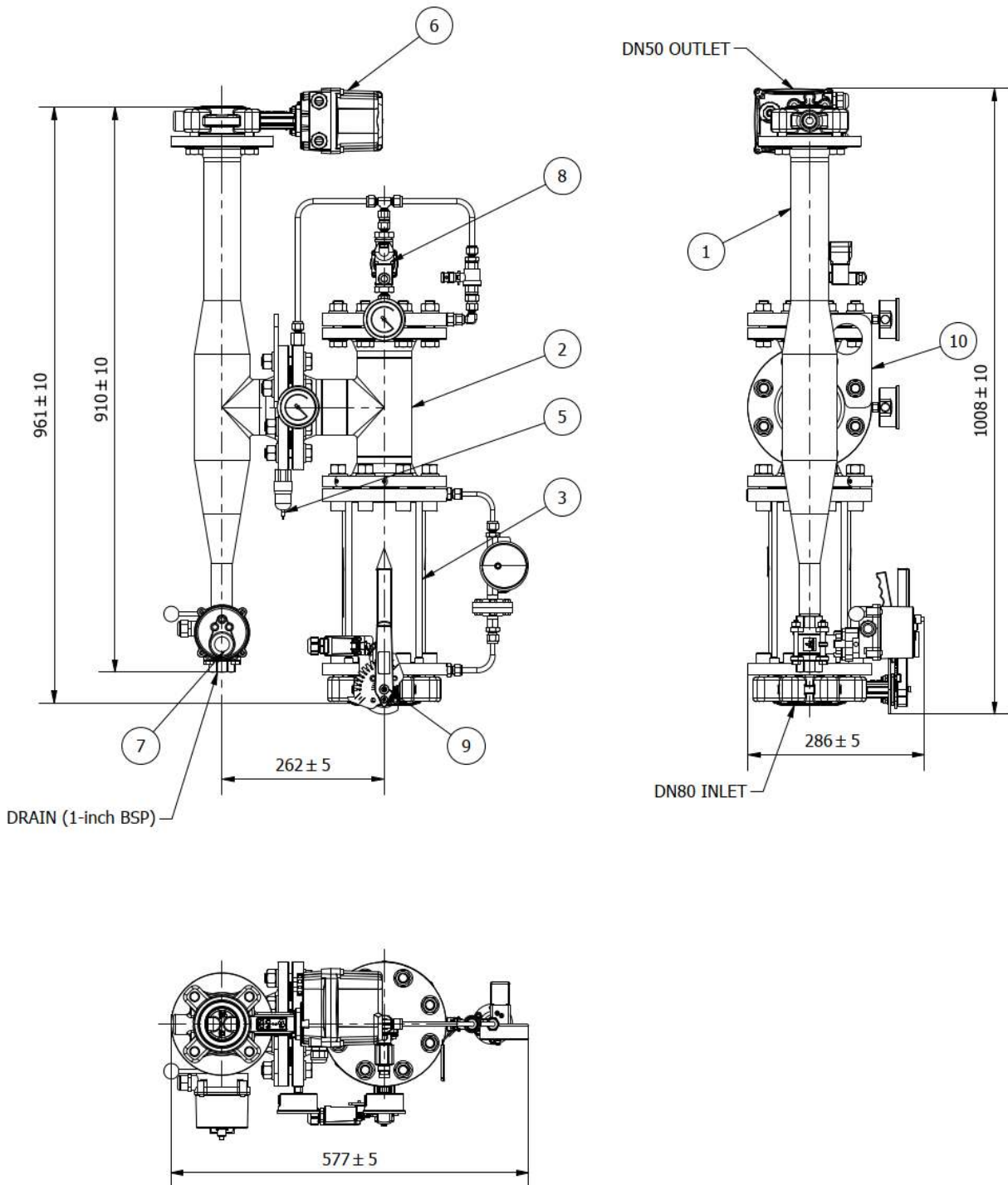

**Contact**

For more information on the Model Tunprotec-C-A-80-50-I, and the TUNPROTEC system and its components, kindly contact the TUNPROTEC sales team at [sales@vidfirekill.com](mailto:sales@vidfirekill.com)

*Disclaimer: VID Fire-Kill APS is not responsible for any errors or omissions, or for the results obtained from the use of this information. All information in this document is provided "as is", with no guarantee of completeness, accuracy, functionality, timeliness or of the results obtained from the use of this information.*